

CR Owner's Manual

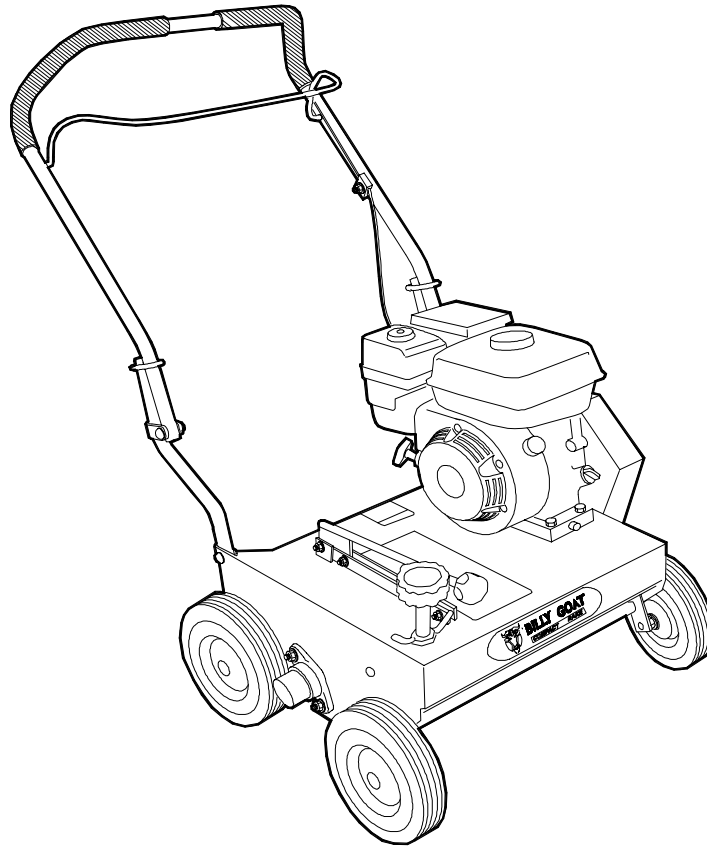

BILLY GOAT CR550HC POWER RAKE

Owner's Manual

Replacement Parts

Accessories

| SLICING REEL | SLICING BLADES | SPACER BUMPERS | DRIVE BELT | FLAIL BLADES | FLAIL SHAFTS |
|--|--|--|---|--|---|
| A complete verti-slicing reel for your CR. 20" wide reel for use in grasses that require vertical cutting, and for assisting in lawn overseeding projects. | A full set of twenty blades for replacement. Includes 40 new cap screws, and lock nuts for replacement installation. | A complete replacement set. 44 of 1/2" spacer bumpers and 4 of 1/4" spacer bumpers | <i>Original Equipment drive belt for your CR.</i> | A complete replacement set. 52 of our high quality flail blades for your CR. Includes 8 new lock clips for replacement installation. | A full set of four shafts for replacement. Includes 8 new lock clips for replacement installation. Note: We recommend replacing the shafts when you replace flails. |
| P/N 350252 | P/N 350187 | P/N 350258 | P/N 350207 | P/N 350251 | P/N 350185 |



CR Owner's Manual

ABOUT THIS MANUAL

THANK YOU for purchasing a BILLY GOAT® CR Power Rake. Your new machine has been carefully designed and manufactured to provide years of reliable and productive service. This manual provides complete operating and maintenance instructions that will help to maintain your machine in top running order. Read this manual carefully before assembling, operating, or servicing your equipment.

CONTENTS

| | |
|--|-------|
| SERIAL PLATE DATA AND SPECIFICATIONS _____ | 3 |
| GENERAL SAFETY _____ | 4-5 |
| SOUND AND VIBRATION _____ | 6 |
| INSTRUCTION LABELS _____ | 7 |
| PACKING CHECKLIST & ASSEMBLY _____ | 8 |
| OPERATION _____ | 9-10 |
| MAINTENANCE _____ | 11 |
| TROUBLESHOOTING AND WARRANTY PROCEDURE _____ | 12 |
| ILLUSTRATED PARTS & PARTS LISTS _____ | 13-16 |





CR Owner's Manual

SERIAL PLATE DATA

Record the model number, serial number, date of purchase, and where purchased.

Purchase Date: _____

Purchased From: _____

| | | | | |
|---|---|--|--|--|
|  |  | | 1803 S.W. Jefferson Lee's Summit, MO 64082 / USA Tel (816) 524-9666 Fax (816) 524-6983 | |
| | Model <input type="text"/> | Serial No. <input type="text"/> | | |
| Unit (Weight) <input type="text"/> lbs. <input type="text"/> kg | | Engine Power <input type="text"/> kW <input type="text"/> rpm | | |

Specifications

CR550HC

| | |
|--------------------------------|--------------------------------|
| Engine: HP | 5.0 (3.73 kW) |
| Engine: Model | GC160AQHA |
| Engine: Type | HONDA OHC |
| Engine: Fuel Capacity | 2.1 qt (2.0 L) |
| Engine: Oil Capacity | 0.63 qt. (0.6 L) |
| Total Unit Weight: | 125# (56.8 kg) |
| Max. operating slope | 20° |
| Lwa at operator position | 99 dB(a) |
| Lpa at operator position | 81 dB(a) |
| Vibration at operator position | 1.01g (9.94 m/s ²) |



CR Owner's Manual

GENERAL SAFETY INSTRUCTIONS and SYMBOLS

The safety symbols shown below are used throughout this manual. You should become familiar with them before assembling, operating, or servicing this equipment.



WARNING: This symbol indicates important information that will prevent injury to yourself or others.



This symbol indicates ear protection is recommended when operating this equipment.



This symbol indicates eye protection is recommended when operating this equipment.



This symbol indicates gloves should be worn when servicing this equipment.



This symbol indicates that this manual and the engine manufacturer's manual should be read carefully before assembling, operation, or servicing this equipment.



CAUTION: This symbol indicates important information that will prevent damage to your BILLY GOAT[®] CR Power Rake.



This symbol indicates the engine oil level should be checked before operating this equipment.

Read and make sure you thoroughly understand the following safety precautions before assembling, operating or servicing this equipment:



READ this manual and the engine manufacturer's manual carefully before assembling, operating, or servicing this equipment.



EAR PROTECTION is recommended when operating this equipment.



EYE PROTECTION is recommended when operating this equipment.



BREATHING PROTECTION is recommended when operating this equipment.



WARNING: **EXHAUST** from this product contains chemicals known to the State of California to cause cancer, birth defects or other reproductive harm.

DO NOT operate this equipment on any unimproved forested, brushy, or grass covered land unless a spark arrester is installed on the muffler as required by Section 4442 of the California Public Resources Code. The arrester must be maintained in good working order. Other states may have similar laws. Federal laws apply on federal lands.



DO NOT run engine in an enclosed area. Exhaust gases contain carbon monoxide, an odorless and possibly fatal poison.



CR Owner's Manual



WARNING:

- ⊘ **DO NOT** run this equipment indoors or in any poorly ventilated area. Refueling outdoors is recommended.
 - ⊘ **DO NOT** refuel this equipment while the engine is running. Allow engine to cool for at least two minutes before refueling.
 - ⊘ **DO NOT** store gasoline near an open flame.
 - ⊘ **DO NOT** remove gas cap while engine is running.
 - ⊘ **DO NOT** start or operate engine if strong odor of gasoline is present.
 - ⊘ **DO NOT** start or operate engine if gasoline is spilled. Move equipment away from spill until gasoline has completely evaporated.
 - ⊘ **DO NOT** smoke while filling the fuel tank.
 - ⊘ **DO NOT** check for spark with spark plug or spark plug wire removed. Use an approved spark tester.
 - ⊘ **DO NOT** operate engine without a muffler. Inspect muffler periodically and replace if necessary. If equipped with muffler deflector, inspect deflector periodically and replace if necessary.
 - ⊘ **DO NOT** operate engine with grass, leaves or other combustible material near the muffler.
 - ⊘ **DO NOT** touch muffler, cylinder, or cooling fins when hot. Contact with hot surfaces may cause severe burns.
 - ⊘ **DO NOT** leave equipment unattended while in operation.
 - ⊘ **DO NOT** park equipment on a steep grade or slope.
 - ⊘ **DO NOT** operate equipment with bystanders in or near the work area.
 - ⊘ **DO NOT** allow children to operate this equipment.
 - ⊘ **DO NOT** operate equipment with guards removed.
 - ⊘ **DO NOT** operate equipment near hot or burning debris or any toxic or explosive materials.
 - ⊘ **DO NOT** operate equipment on slopes greater than specified in Specifications section of this manual.
 - ⊘ **DO NOT** start engine without height adjust lever in up position and clutch bail disengaged.
 - ⊘ **DO NOT** place hands or feet underneath unit, or near any moving parts.
- ALWAYS** remove spark plug wire when servicing equipment to prevent accidental starting.
- ALWAYS** check fuel lines and fittings frequently for cracks or leaks. Replace if necessary.
- ALWAYS** keep hands and feet away from moving or rotating parts.
- ALWAYS** store fuel in approved safety containers.
-  **WARNING: Important**
Remove all rocks, wire, string, etc. that can present a hazard during work prior to starting.
-  **DO** identify and mark all fixed objects to be avoided during work such as sprinkler heads, water valves, buried cables, or clothes line anchors, etc.



CR Owner's Manual

SOUND



L_{WA}
99 dB

SOUND LEVEL 81 dB(a) at Operator Position

Sound tests were conducted in accordance with 2000/14/EEC, and were performed on 2-9-2002 under the conditions listed below.

⚠ Sound power level listed is the highest value for any model covered in this manual. Please refer to serial plate on the unit for the sound power level for your model.

| | |
|----------------------|---------------------|
| General Conditions: | Sunny |
| Temperature: | 43°F (6.1°C) |
| Wind Speed: | 10 mph (16.1 kmh) |
| Wind Direction: | North West |
| Humidity: | 82.2% |
| Barometric Pressure: | 29.72Hg (754 mm Hg) |

VIBRATION DATA

VIBRATION LEVEL 1.01g (9.94m/s²)

Vibration levels at the operator's handles were measured in the vertical, lateral and longitudinal directions using calibrated vibration test equipment. Tests were performed on 5-25-2006 under the conditions listed below.

| | |
|----------------------|-------------------|
| General Conditions: | Sunny |
| Temperature: | 72.32°F (22.4°C) |
| Wind Speed: | 3.8 mph (6.12kph) |
| Wind Direction: | East |
| Humidity: | 62.2% |
| Barometric Pressure: | 29.9Hg (101.3kpa) |

INTENDED USE

INTENDED USE: This machine is designed for removing thatch from your lawn, renovation of existing lawns, and to assist in overseeding operations. The machine should not be used for any other purpose than that stated above.

Do not operate if excessive vibration occurs. If excessive vibration occurs, shut engine off immediately and check for damaged or worn reel, loose pulley bolts or set screws, loose engine or lodged foreign objects. (See trouble shooting section on page 12).



CR Owner's Manual

INSTRUCTION LABELS

The labels shown below were installed on your BILLY GOAT® CR Power Rake. If any labels are damaged or missing, replace them before operating this equipment. Item numbers from the Illustrated Parts List and part numbers are provided for convenience in ordering replacement labels. The correct position for each label may be determined by referring to the Figure and Item numbers shown.



LABEL DANGER KEEP HANDS AND FEET AWAY
ITEM #51 P/N 400424



LABEL CLUTCH ITEM #49
P/N 830503



DANGER FLYING DEBRIS
ITEM # 48 P/N 810736



LABEL CAUTION GUARD
ITEM #52 P/N 900327



LABEL EXPLOSIVE FUEL
ITEM # 50 P/N 400268

LABEL INSTRUCTION HEIGHT ADJ.
ITEM #35 P/N 350224

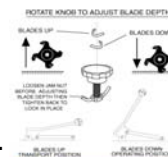

ENGINE LABELS/CONTROLS

HONDA

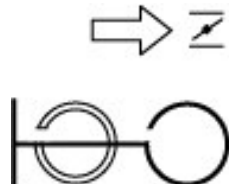

■ READ OWNER'S MANUALS BEFORE OPERATION.
 ■ LIRE LE MANUEL D'UTILISATEUR AVANT USAGE.
 ■ VOR INBETRIEBNAHME UNBEDINGT BEDIENUNGSANLEITUNG DURCHLESEN.
 ■ NO UTILIZAR SIN ANTES NO HABER LEIDO EL MANUAL.



CR Owner's Manual

PACKING CHECKLIST

Your Billy Goat Power Rake is shipped from the factory in one carton, completely assembled.



READ all safety instructions before assembling unit.

TAKE CAUTION when removing the unit from the box the Handle Assembly is attached and folded over



PUT OIL IN ENGINE BEFORE STARTING

PARTS BAG & LITERATURE ASSY

Warranty card P/N- 400972, Owner's Manual P/N-350245, Declaration of Conformity P/N-350139, and Literature CR Accessories 350246.

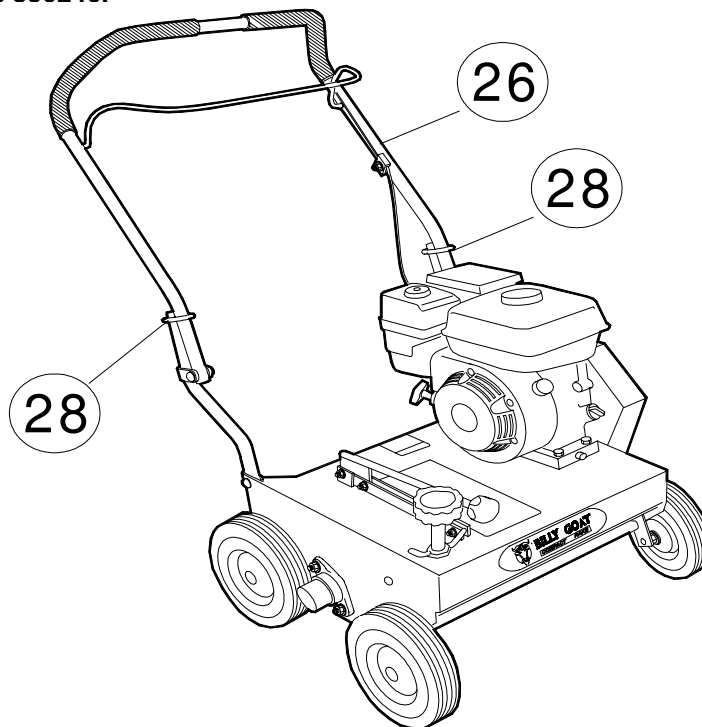

Boxing Parts Checklist

- Honda GC 5.0 OHC
- Literature Assy P/N-350243

ASSEMBLY

1. **ASSEMBLE** the left rear wheel to the axle using $\frac{3}{4}$ " wrench.
2. **UNFOLD** the upper handle (item 26) and slide handle lock loops (item 28) into place to secure the upper handle to the lower.
3. **CHECK** engine oil level and fill to proper level with engine manufacturers recommended grade of oil. Move height adjust lever to down position, to level engine during checking. See engine manufacturers instruction manual.
4. **CONNECT** spark plug wire.



CR Owner's Manual

OPERATION

Like all mechanical tools, reasonable care must be used when operating machine.

Inspect machine work area and machine before operating. Make sure that all operators of this equipment are trained in general machine use and safety.

PUT OIL IN ENGINE BEFORE STARTING

STARTING

ENGINE: See engine manufacturer's instructions for type and amount of oil and gasoline used. Engine must be level when checking and filling oil and gasoline.

FUEL VALVE: Move fuel valve to "ON" position (when provided on engine).

STOP SWITCH: Located on the engine. "slow/stop" position.

CHOKE: Operated with choke lever on side of engine.

THROTTLE: Controlled by throttle lever on the motor.

IF YOUR UNIT FAILS TO START:

See Troubleshooting on page 12.

FOLDING HANDLE

This unit is equipped with a folding upper handle for easier storage and transportation. The handle can be folded by sliding the handle lock loops (item 28) up. This releases the upper handle, allowing it to be folded over the unit.

HANDLING & TRANSPORTING:

This unit requires two people to lift it. With the handle in the folded position, lift holding the lower handle and belt/shaft guard one on each side of the machine. Secure the machine in place during transport. See page 3 for weight specifications

Never lift the machine while the engine is running.

BLADE POSITION & DEPTH CONTROL LEVER

The blades can be raised or lowered into the ground by height adjustment lever on the engine base. The resulting blade depth can be adjusted higher or lower. See ADJUSTING BLADE DEPTH.

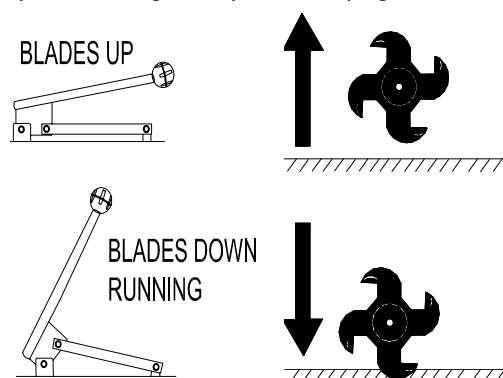

ADJUSTING BLADE DEPTH

The depth of the blades can be raised or lowered by rotating the knob on the top of the adjustment lever. The blades are lowered by rotating the knob counter-clockwise, and raised by rotating the knob clockwise. The relative depth of the blades can be gauged by using the depth scale located on the right front corner of the engine base.

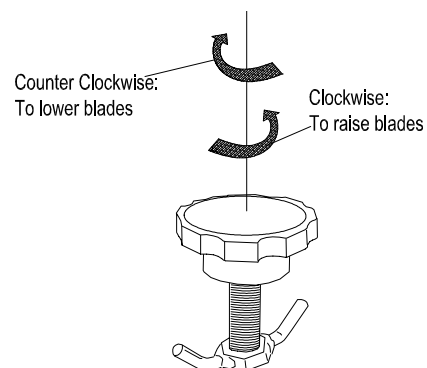



CR Owner's Manual

RAKING OPERATION

MOW: Mow the lawn to its normal cut height

DRY: Be sure grass is dry. Wet conditions can cause increased damage to healthy grass.

SET DEPTH: With engine off, set the raking depth so that the blades just touch on a flat surface (i.e. driveway, or sidewalk).

START ENGINE: See page 9.

ENGAGE BLADES: Pull back on the bail on the operators handle. **NOTE:** When engaging the blades in heavy load conditions (i.e. heavy thatch, or very uneven turf), push down on the operators handle lifting the front wheels slightly. Engage the blades. Slowly lower the unit into the turf.

RAKE: Rake a small test area and examine the results. Thatch should be removed and deposited on top of the healthy grass. If excessive damage occurs to healthy grass, adjust the blade depth to decrease damage. Continue raking the yard, working in one direction (i.e. north-south, or east-west). **NOTE:** If a large drop in engine RPM occurs, or the unit pulls you forward and bounces during operation the blade depth is set too low.

REMOVE THATCH: After raking, a layer of thatch will be deposited over the top of the lawn. This thatch must be removed prior to any fertilizing, seeding, or watering of the lawn. We suggest the use of a lawn vacuum or wheeled blower for collection and removal of the thatch.

VERTI-CUTTING OPERATION

MOW: Mow the lawn to its normal cut height

DRY: Be sure grass is dry. Wet conditions can cause increased damage to healthy grass.

SET DEPTH: With engine off, set the raking depth so that the blades just touch on a flat surface (i.e. driveway, or sidewalk).

START ENGINE: See Page 9.

ENGAGE BLADES: Pull back on the bail on the operators handle. **NOTE:** When engaging the blades in heavy load conditions (i.e. heavy thatch, or very uneven turf), push down on the operators handle lifting the front wheels slightly. Engage the blades. Slowly lower the unit into the turf.

SLICE: Verti-cut a small test area and examine the results. Some thatch and cut stems should be removed and deposited on top of the healthy grass. Grass runners should be cut and ready for removal. If excessive damage occurs to healthy grass, adjust the blade depth to decrease damage. Continue raking the yard, working in one direction (i.e. north-south, or east-west). **NOTE:** If a large drop in engine RPM occurs, or the unit pulls you forward and bounces during operation the blade depth is set too low.

REMOVE THATCH/STEMS: After verti-cutting, a layer of thatch and cut stems will be deposited over the top of the lawn. We suggest the use of a lawn vacuum or wheeled blower for collection and removal of the thatch/stems.

RAKING/SLICING TIPS

THATCH: Thatch is a dense layer of dead grass, clippings, and roots that builds up over time at the base of the lawn preventing air, water, and fertilizer from reaching the soil. This can cause shallow root development and make a lawn more susceptible to drought and disease. Thatch also provides an ideal environment for insects to hide and multiply. Periodic removal of thatch will keep your lawn in good health.

HEAVY THATCH: Lawns with an excessive amount of thatch will require multiple treatments for effective removal.

Trying to remove excessive thatch (greater than 3/4"[19 mm] deep) in one treatment will damage or destroy the living part of the lawn. It is best to remove heavy thatch in seasonal treatments (i.e. spring, and fall).

CHECK: Before beginning, it is best to evaluate the condition of the lawn by cutting one or more core samples from area to be treated. A core can be cut using a piece of pvc, or metal pipe. Hammer the pipe into the ground, remove it, push the core out of the pipe and inspect it to determine the depth of thatch in your yard.

SLOPES: Rake slopes across not up and down. This is much easier and safer for the operator and is better for the lawn. Raking across will help to reduce runoff during watering and allow the sloped ground to hold more seed, fertilizer, and water. The units maximum operating slope is 35% or 19°.

DEPTH: The wide range of depth adjustment on your unit is provided to allow for blade wear. Setting the reel deeper will not produce better, or quicker results. The flail reel is intended to be set so it just touches the surface on flat ground. The slicing reel should be set even with the ground for verti-slicing work, and set to a maximum 1/2" depth for overseeding jobs. Setting the reel deeper than this will only result in premature wear on the unit (i.e. failed belt). If you desire to work the ground deeper than the above guidelines allow, it should be done gradually in multiple passes.



CR Owner's Manual

MAINTENANCE

PERIODIC MAINTENANCE

Periodic maintenance should be performed at the following intervals:

| Maintenance Operation | Every Use (daily) | Every 25 Hours |
|---|-------------------|----------------|
| Inspect for loose, worn or damaged parts. | | ● |
| Check engine oil | ● | |
| Inspect belt | | ● |
| Engine (See Engine Manual) | | |
| Grease reel bearings | | ● |
| Inspect and clean engine air filter | ● | |
| Oil height adjustment linkage | | ● |

FLAIL BLADE WEAR

1. Wait for engine to cool and disconnect spark plug.
2. Close fuel valve on engine. (Honda only)
3. Lean unit back onto lower handles and secure in place.
4. Inspect blades for wear, and immediately replace any bent or cracked blades. Measure the overall length of the blade. (See fig. 1)
5. If blades measure less than 3.0"(76 mm) in overall length they must be replaced. NOTE: We recommend replacing all the flails at once.

SLICING BLADE WEAR

1. Wait for engine to cool and disconnect spark plug.
2. Close fuel valve on engine. (Honda only)
3. Lean unit back onto lower handles and secure in place.
4. Inspect blades for wear, and immediately replace any bent or cracked blades. Measure the overall length of the blade from the center of the attachment bolts to the tip of the worn blade.
5. If blades measure less than 3.0"(76 mm) they must be replaced. NOTE: We recommend replacing all the blades at once.

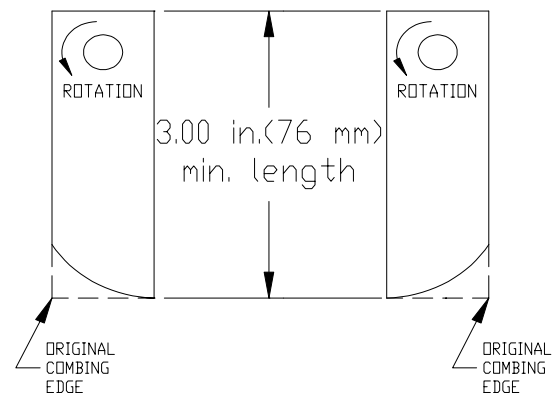

Fig. 1

ROTATING FLAIL REEL END TO END

To maximize flail blade life and performance the reel can be rotated end to end periodically to provide a fresh lead cutting edge. Takes approx. 20 min. and requires two 1/2" socket wrenches with extension bar.

1. Wait for engine to cool and disconnect spark plug.
2. Close fuel valve on engine.
3. Lean unit back onto lower handles and secure in place.
4. Remove (6) lock nuts (item 62) holding the belt and shaft guards (item 21 & 22) in place. It is necessary to lower the height adjust lever to reach the locknuts on the guards. Remove the guards.
5. Remove the drive belt (item 9) by "walking" it out of the groove on the reel pulley (item 2).
6. Remove the (4) lock nuts (item 60) and washers (item 68) holding the bearings (item 23) to the frame of the unit.
7. The reel is now free from the machine. Slide the reel down and out of the machine.
8. Remove the capscrew (item 71), lockwasher (item 57), reel pulley (item 2), key (item 42), and reel spacer (item 10) from the end of the reel.
9. Rotate the reel end to end, and re-install these items on the opposite end of the reel.
10. Re-install the reel in reverse order of removal. Re-install the guards in reverse order of removal.

DRIVE BELT REPLACEMENT

NOTE: Takes approx. 10 min. and requires 3/8" socket wrench with extension.

1. Wait for engine to cool and disconnect spark plug.
2. Remove (6) self-tapping screws (item 65) holding the belt guard (item 21 & 22) in place. Remove the guard.
3. Remove the belt (item 9) by rotating the reel pulley (item 2) and walking it out of the groove. Discard old belt
4. Install new belt using same procedure to walk the belt into the groove.
5. With new belt installed pull bail rod back to engaged position and measure extension of idler spring. Spring should stretch 1" to 1.25" (25-32 mm) with bail engaged. Adjust clutch cable as necessary to achieve this extension.
6. Re-install the belt guard.



CR Owner's Manual

STORAGE

⚠ Never store engine indoors or in enclosed poorly ventilated areas with fuel in tank, where fuel fumes may reach an open flame, spark or pilot light, as on a furnace, water heater, clothes dryer or other gas appliance.

If engine is to be unused for 30 days or more, prepare as follows:

⚠ Remove all gasoline from carburetor and fuel tank to prevent gum deposits from forming on these parts and causing possible malfunction of engine. Drain fuel outdoors, into an approved container, away from open flame. Be sure engine is cool. Do not smoke. Run engine until fuel tank is empty and engine runs out of gasoline.

Troubleshooting

| Problem | Possible Cause | Solution |
|---------------------------------------|--|---|
| Abnormal vibration. | · Damaged or missing blades. Loose handle bolts. Loose engine bolts | · Stop work immediately. Replace any damaged or missing blades. Tighten all loose nuts and bolts. |
| Engine stalls or labors when raking | · Blades set too deep into ground. | · Raise blades so that they just touch the ground on a level surface |
| Engine will not start. | · Throttle in off position · Out of gasoline or bad, old gasoline. · Spark Plug wire disconnected. · Gas valve off. · Dirty air cleaner. | · Check choke position. · Check gasoline. · Connect spark plug wire. · Turn on gas valve. · Clean or replace air cleaner. Contact a qualified service person. |
| Engine is locked, will not pull over. | · Debris locked against reel, or drive pulleys. Engine problem. | · Pull spark plug wire and remove debris. Contact an engine servicing dealer for engine problems. |

When servicing engine refer to specific manufacturers engine owner's manual. Engine warranty is covered by the specific engine manufacturer. If your engine requires warranty or other repair work contact your local servicing engine dealer. When contacting a dealer for service it is a good idea to have your engine model number available for reference (See table page 3). If you cannot locate a servicing dealer in your area you can contact the manufacturers national service organization.

To reach:

American Honda: 800-426-7701

WARRANTY CLAIM PROCEDURE

Should a BILLY GOAT[®] machine fail due to a defect in material and/or workmanship, the owner should make a warranty claim as follows:

- The machine must be taken to the dealer from whom it was purchased or to an authorized Servicing BILLY GOAT Dealer.
- The owner must present the remaining half of the Warranty Registration Card, or, if this is not available, the invoice or receipt.
- The Warranty Claim will be completed by the authorized BILLY GOAT Dealer and submitted to their respective BILLY GOAT Distributor for their territory Attention: Service Manager. Any parts replaced under warranty must be tagged and retained for 90 days. The model number and serial number of the unit must be stated in the Warranty Claim.
- The distributor service manager will sign off on the claim and submit it to BILLY GOAT for consideration.
- The Technical Service Department at BILLY GOAT will study the claim and may request parts to be returned for examination. BILLY GOAT will notify their conclusions to the distributor service manager from whom the claim was received.
- The decision by the Technical Service Department at BILLY GOAT to approve or reject a Warranty Claim is final and binding.

For online product registration go to www.billygoat.com



CR Owner's Manual

PARTS DRAWING CR550HC

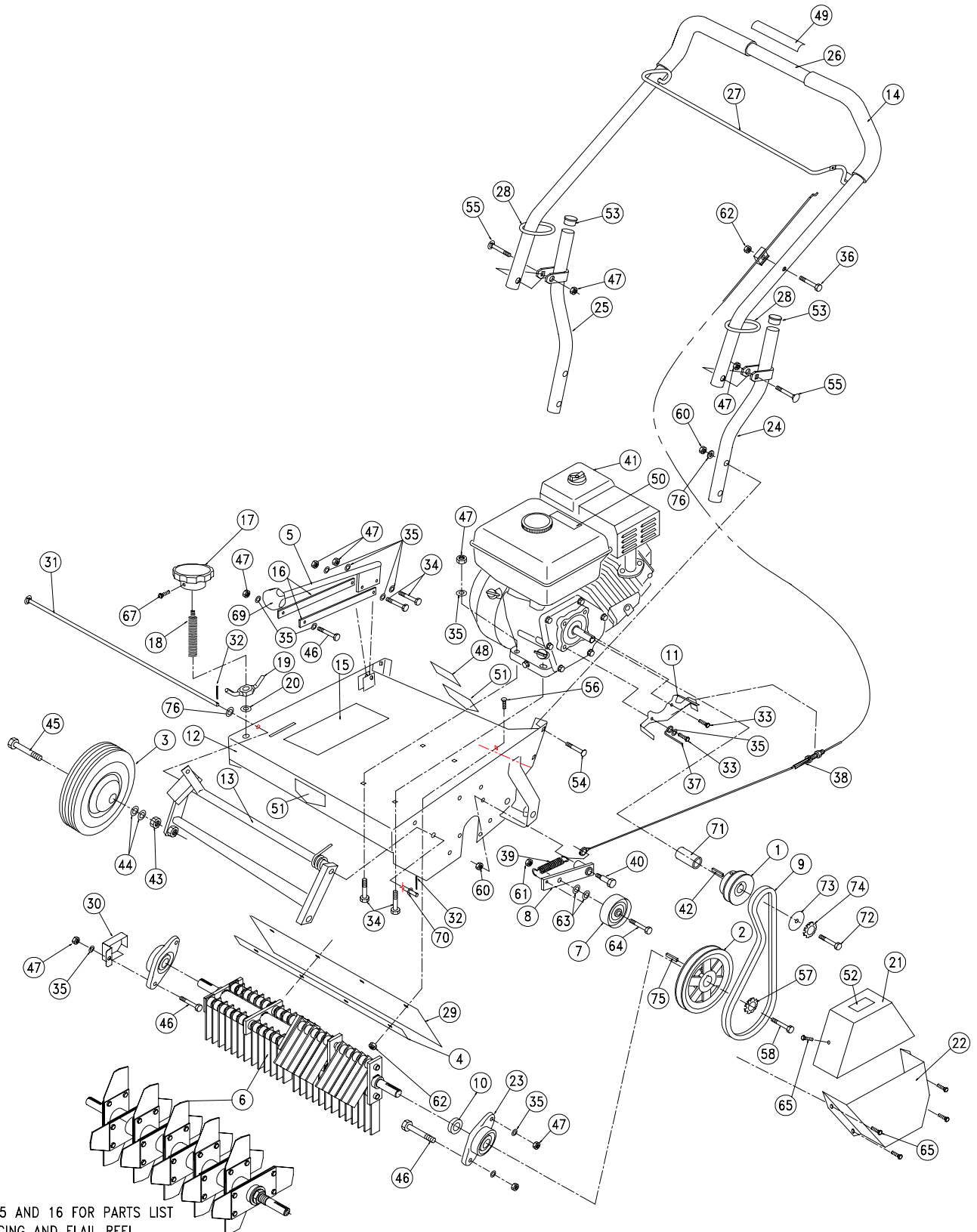

SEE PAGE 15 AND 16 FOR PARTS LIST
FOR SLICING AND FLAIL REEL



CR Owner's Manual

PARTS LIST

| item no. | PARTS LIST | CR 550HC Part No. | QTY |
|----------|---|-------------------|-----|
| 1 | Pulley 3.0" O.D. | 350101 | 1 |
| 2 | Pulley 5.5" O.D. X 3/4" | 350206 | 1 |
| 3 | Wheel 8" Semi-Pneu White | 350236 | 4 |
| 4 | Bar Strap | 350211 | 1 |
| 5 | Rod Height Wa | 350220 | 1 |
| 6 | Reel Flail Assy (see page 10 & 11 for parts list and detailed dwg.) | 350241 | 1 |
| 7 | Pulley Idler 2.75" | 350114 | 1 |
| 8 | Arm Idler WA | 350115 | 1 |
| 9 | Belt 5L X 34" | 350207 | 1 |
| 10 | Spacer Reel Pulley | 350118 | 1 |
| 11 | Bracket Belt Finger | 350208 | 1 |
| 12 | Chassis WA W / Label | 350235 | 1 |
| 13 | Frame Front WA | 350213 | 1 |
| 14 | GRIP 1" x 13" | 400570 | 2 |
| 15 | Label Instr. Hgt. Adj. | 350224 | 1 |
| 16 | Link Height Bar | 350223 | 2 |
| 17 | Knob Height Adj. | 850154 | 1 |
| 18 | STUD 3/4"-10 X 5 1/2" PLTD | 810538 | 1 |
| 19 | LOCKNUT ASSY | 800227 | 1 |
| 20 | WASHER 3/4" NYLON | 800109 | 1 |
| 21 | Guard Belt Top Wa | 350248 | 1 |
| 22 | Guard Belt Bottom Wa | 350249 | 1 |
| 23 | Bearing 3/4" Cast Flange | 350209 | 2 |
| 24 | Handle Lower LH WA | 350134 | 1 |
| 25 | Handle Lower RH WA | 350135 | 1 |
| 26 | Handle Upper PR500 | 350136 | 1 |
| 27 | Bail Clutch WA | 350137 | 1 |
| 28 | Loop Folding Handle | 350138 | 2 |
| 29 | Deflector Rubber | 350210 | 1 |
| 30 | Guard Shaft CR | 350250 | 1 |
| 31 | PIN LIFT FRONT 3/8" X 21 3/16" Long | 350212 | 1 |
| 32 | PIN COTTER 1/8" X 1" Z/P | 900471 | 1 |
| 33 | SCREW CAP 5/16-24x3/4" GR5 | 8042026 | 2 |
| 34 | SCREW CAP 5/16 - 18 x 1 1/2 | 8041030 | 6 |
| 35 | WASHER 1/4" FLAT Z/P | 8171002 | 13 |
| 36 | SCREW CAP 1/4"-20X1.5" | 8041008 | 1 |
| 37 | BELT FINGER WIRE | 350301 | 1 |
| 38 | Cable Clutch Reel PR500 | 350181 | 1 |
| 39 | Spring Extension | 350300 | 1 |
| 40 | Bolt Shoulder 1/2" X 1" | 500114 | 1 |
| 41 | ENGINE HONDA 5.0 HP GC | 430272 | 1 |
| 42 | KEY 3/16" X 1" | 9201078 | 1 |
| 43 | NUT 1/2 - 13 JAM | 8162005 | 4 |
| 44 | WASHER 1/2 SAE | 8172011 | 8 |
| 45 | SCREW CAP 1/2-13 x 3" Z/P | 8041102 | 4 |
| 46 | SCREW CAP 5/16"-18X1 1/4" HCS ZP | 8041029 | 5 |
| 47 | NUT LOCK 5/16-18 | 8160002 | 13 |
| 48 | LABEL DANGER THROWN OBJECT | 810736 | 1 |
| 49 | LABEL CLUTCH VQ | 830503 | 1 |
| 50 | LABEL HOT ENGINE | 400268 | 1 |
| 51 | LABEL WARNING | 400424 | 2 |
| 52 | LABEL DANGER GUARD | 900327 | 1 |
| 53 | PLUG CAP 1" RD | 890132 | 2 |
| 54 | BOLT CARRAIGE 3/8-16 x 1 3/4 | 8024061 | 4 |
| 55 | BOLT CARRAIGE 5/16-18 x 1 3/4 | 8024043 | 2 |
| 56 | SCREW CAP 1/4-20x1" | 8041006 | 4 |
| 57 | LOCK WASHER TWISTED TOOTH | 400502 | 1 |
| 58 | SCREW CAP 3/8-16x1" REEL ASSEMBLY | 8041050 | 1 |
| 60 | NUT LOCK 3/8-16 | 8160003 | 5 |
| 61 | NUT LOCK 3/8-16 THIN | 8161042 | 1 |
| 62 | NUT LOCK 1/4-20 | 8160001 | 5 |
| 63 | WASHER 5/16 FLAT CUT | 8171003 | 2 |
| 64 | SCREW CAP 3/8-16x1.5" | 8041052 | 1 |
| 65 | SCREW CAP SHEET METAL DRILL POINT 1/4X3/4 | 430208 | 6 |
| 66 | | | |
| 67 | SCREW MACH. #10-24X2" | 8059143 | 1 |
| 68 | | | |
| 69 | Knob Height Adj. | 430128 | 1 |
| 70 | WASHER 5/16 SAE | 8172009 | 1 |
| 71 | SPACER CRANK CR HONDA | 350338 | 1 |
| 72 | SCREW CAP 5/16-24 x 1 1/4" GR. 8 | 400389 | 1 |
| 73 | WASHER FENDER 5/16 | 8172020 | 1 |
| 74 | WASHER TWISTED TOOTH | 400389 | 1 |
| 75 | KEY 3/16" X 5/8" | 9201072 | 1 |
| 76 | 3/8 FLAT CUT WASHER | 8171004 | 5 |



CR Owner's Manual

FLAIL REEL ASSY 350241

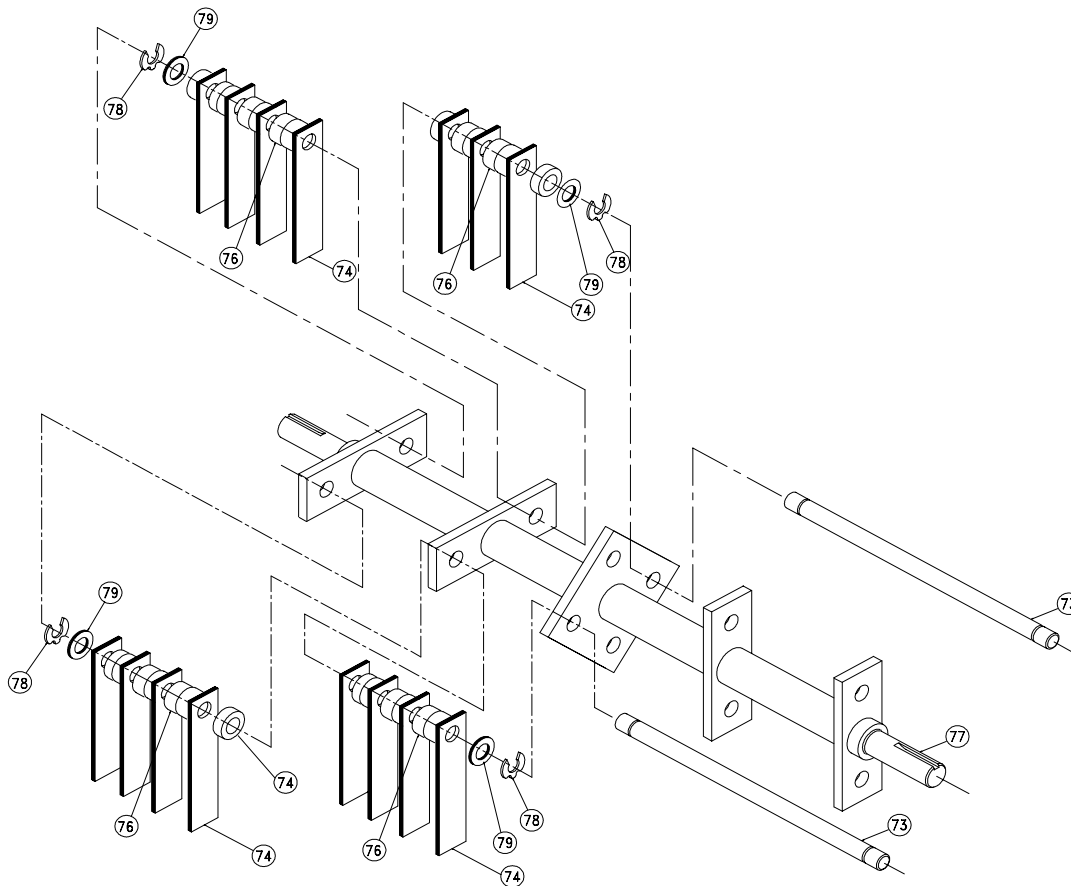

| item no. | PARTS LIST | Part No. | QTY |
|----------|---------------------------|----------|-----|
| 73 | SHAFT FLAIL BLADE | 350141 | 4 |
| 74 | BLADE FLAIL | 350205 | 52 |
| 75 | SPACER BUMPER 5/8" X 1/4" | 350143 | 4 |
| 76 | SPACER BUMPER 5/8" x 1/2" | 350144 | 44 |
| 77 | SHAFT WA FLAIL REEL | 350145 | 1 |
| 78 | CLIP LOCK 1/2" | 350146 | 8 |
| 79 | WASHER 1/2 SAE | 8172011 | 8 |

FLAIL SHAFT KIT 350185

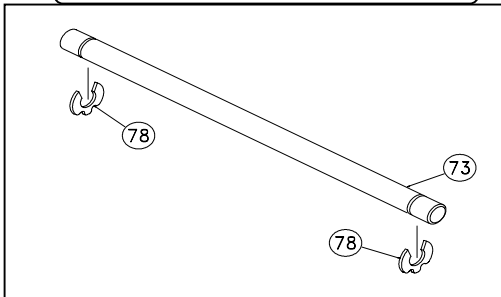

| item no. | PARTS LIST | Part No. | QTY |
|----------|-------------------|----------|-----|
| 73 | SHAFT FLAIL BLADE | 350141 | 4 |
| 78 | CLIP LOCK 1/2" | 350146 | 8 |

FLAIL BLADE KIT 350251

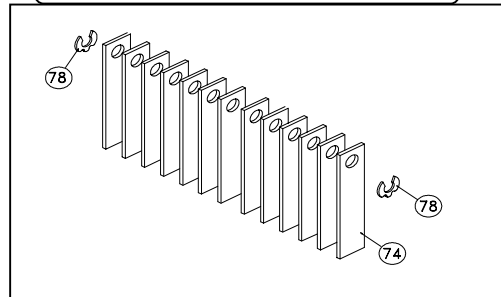

| item no. | PARTS LIST | Part No. | QTY |
|----------|----------------|----------|-----|
| 74 | BLADE FLAIL | 350205 | 52 |
| 78 | CLIP LOCK 1/2" | 350146 | 8 |



CR Owner's Manual

SPACER BUMPER KIT 350258

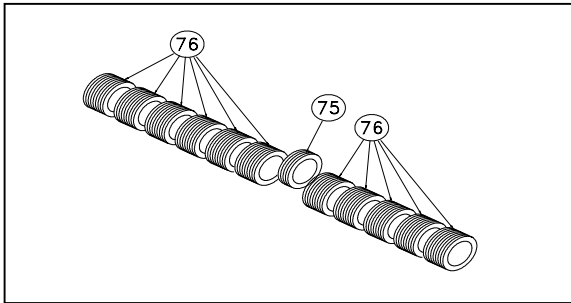

| item no. | PARTS LIST | Part No. | QTY |
|----------|---------------------------|----------|-----|
| 75 | SPACER BUMPER 5/8" x 1/4" | 350143 | 4 |
| 76 | SPACER BUMPER 5/8" x 1/2" | 350144 | 54 |

SLICING BLADE KIT 350187

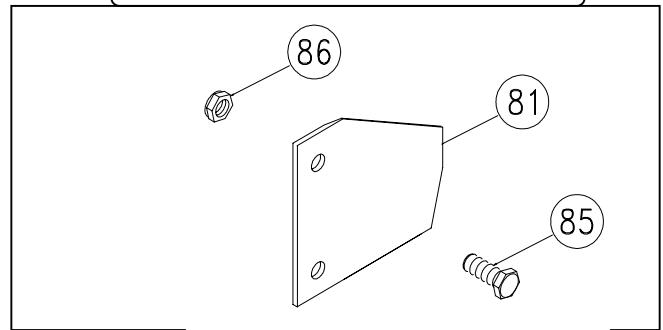

| item no. | PARTS LIST | PR500 Part No. | QTY |
|----------|------------------------------|----------------|-----|
| 81 | BLADE SLICING REEL | 350147 | 20 |
| 85 | SCREWCAP 1/4-20 x 3/4, GR. 5 | 350151 | 40 |
| 86 | NUT LOCK 1/4-20 | 8142004 | 40 |

SLICING REEL ASSY 350252

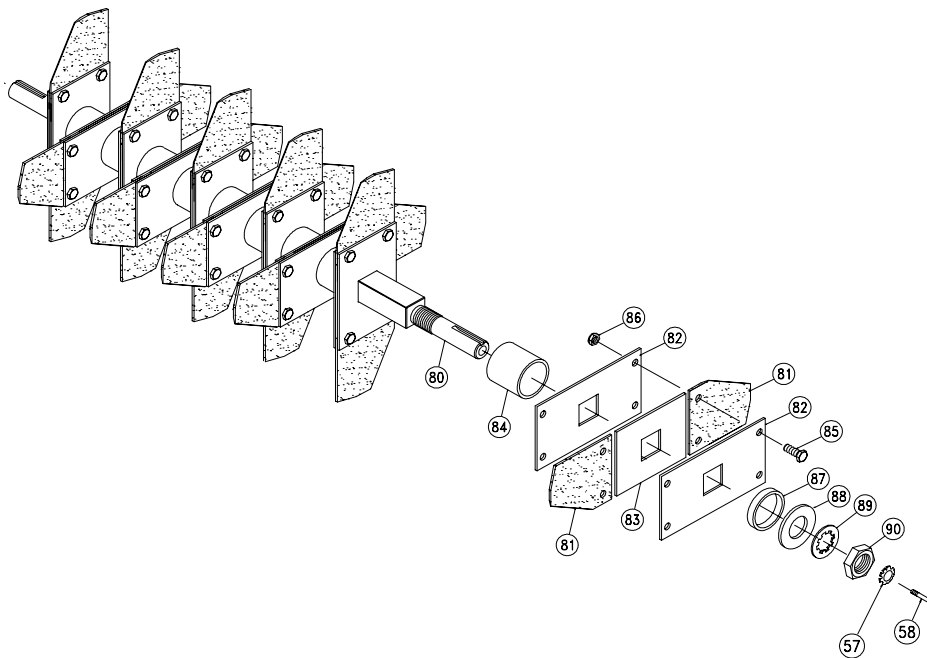

| item no. | PARTS LIST | PR500 Part No. | QTY |
|----------|--------------------------------|----------------|-----|
| 57 | LOCK WASHER 5/16 TWISTED TOOTH | 430298 | 1 |
| 58 | SCREWCAP 5/16 - 24 X 1" GR. 5 | 400164 | 1 |
| 80 | SHAFT SLICING WA | 350142 | 1 |
| 81 | BLADE SLICING REEL | 350147 | 20 |
| 82 | PLATE BLADE MTG. | 350253 | 20 |
| 83 | SPACER BLADE MTG. | 350254 | 10 |
| 84 | SPACER BLADE ASSY | 350150 | 9 |
| 85 | SCREWCAP 1/4-20 x 3/4, GR. 5 | 350151 | 40 |
| 86 | NUT LOCK 1/4-20 | 8142004 | 40 |
| 87 | COLLAR SPACER | 350152 | 1 |
| 88 | WASHER 0.937 x 1.750 x 0.119 | 350153 | 1 |
| 89 | WASHER LOCK 7/8 INT. TOOTH | 350154 | 1 |
| 90 | NUT JAM 7/8-14 | 350155 | 1 |